

1	2	3	4	5	6	7	8
---	---	---	---	---	---	---	---

DESIGN OFFICE	DRAWING NUMBER
---------------	----------------

When a detail is to be completed, first of all the detail and its position in the assembly must be checked. The drawing must be checked for any errors.



MICROFILMED

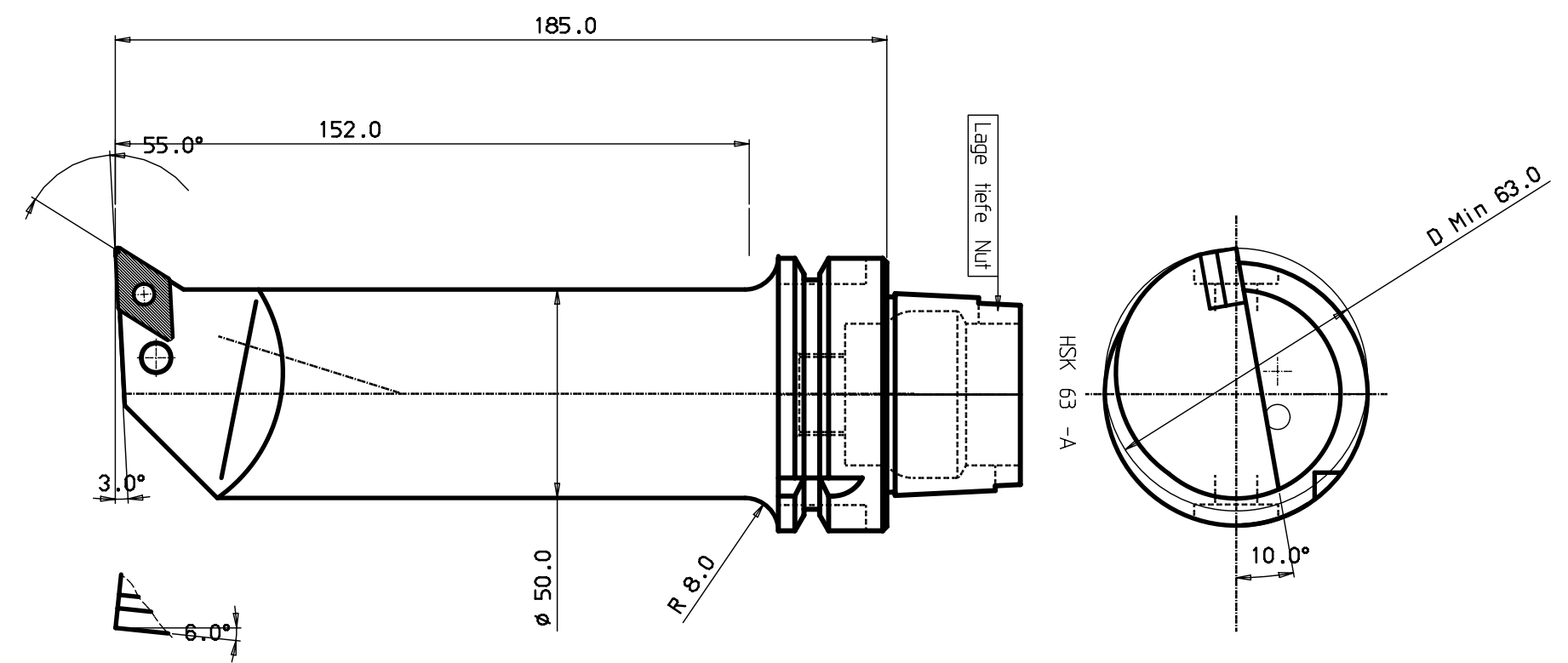

HM-Platte DN.. 1506..

5	1	Schraube	174.3-830
4	1	Rohrstift	174.3-861
3	1	Unterlage	17135-855
2	1	Knihebel	174.3-847M

ITEM	QNTY	DESCRIPTION	MATERIAL AND REMARKS	RELATED DRAWING	ITEM	SIZE
CATEGORY	DESIGNED	DRAWN	CHECKED	DATE	SCALE	SUPERSEDES

Tolerance systems acc to ISO
Surface roughness Ra um

Where tolerance not stated:
For threads SS-iso 965/3
For dimensions SS 715 Medium

Dimension	Tol	Angle (shortest adjacent side in mm)	Tol
-6	±0.10	10	±1'
(6) - 30	±0.20	10	±30'
(30) - 120	±0.30	(50) - 120	±20'
(120) - 315	±0.50	(120) -	±10'
(315) - 1000	±0.80		

TITLE: **Schneidkopf**

REFERENCE	MODIFICATION	DESIGN OFFICE	DRAWING NUMBER
-----------	--------------	---------------	----------------

1	2	3	4	5	6	7	8
---	---	---	---	---	---	---	---