

When a part has been completed, please do not put any  
 other marks on the drawing, as this may lead to confusion.  
 The drawing is the property of the company.

100 mm  
 90  
 80  
 70  
 60  
 50  
 40  
 30  
 20  
 10  
 0

MICROFILMED

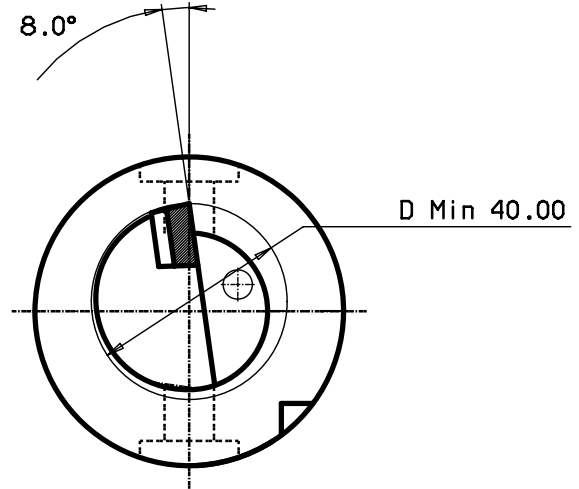
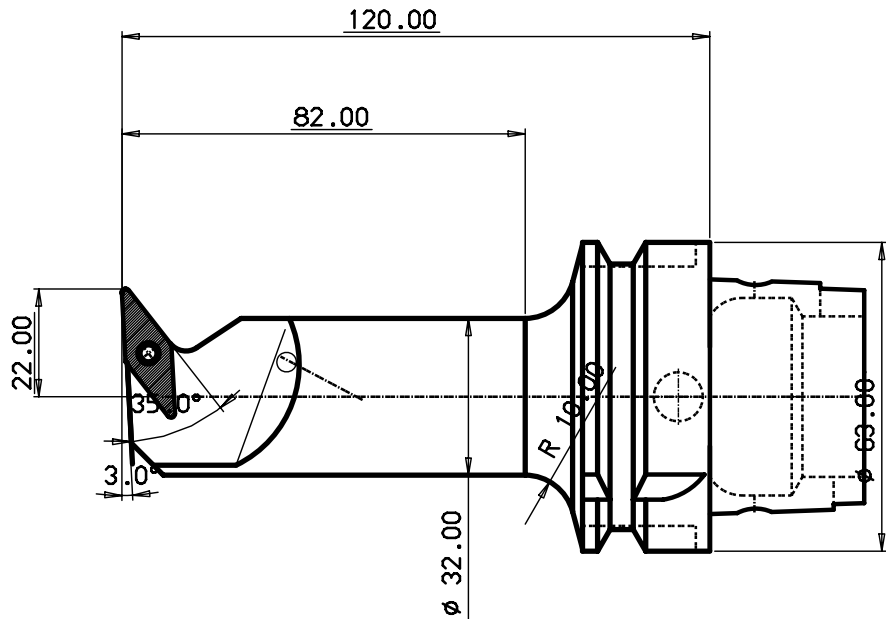

HM-Platte VBMT 160404

ITEM	QNTY	DESCRIPTION	MATERIAL AND REMARKS	RELATED DRAWING	UNIT	ISSUE
4	1	Schraube f. Zw			5512 090-01	
3	1	Zwischenlage			5322 270-01	
2	1	Schraube f. Platte			5513 020-01	
1						

Tolerance systems acc to ISO  
 Surface roughness Ra um

Where tolerance not stated:  
 For threads SS-iso 965/3  
 For dimensions SS 715 Medium

Dimension	Tol	Angle (Shortest adjacent side in mm)	Tol
6) - 30	±0.10	10	± 1'
30) - 60	±0.20	10	± 30'
60) - 95	±0.30	150) - 120	± 20'
95) - 1000	±0.80	120) -	± 20'

ITEM	QNTY	DESCRIPTION	MATERIAL AND REMARKS	RELATED DRAWING	UNIT	ISSUE
CATEGORY	DESIGNED	DRAWN	CHECKED	DATE	SCALE	SUPERSEDES
TITLE						
<b>Schneidkopf Cutting-Unit</b>						
REFERENCE	MODIFICATION	DESIGN OFFICE	DRAWING NUMBER	TITLE		
				<b>HSK63A-SVUBL-2232120-16</b>		

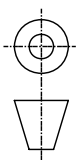

340-07000-2

MOD	LOCATION	CHANGE REFERENCE	DATE	SIGN