

DESIGN OFFICE | DRAWING NUMBER

Show a detail over the complete face of any hole and the hole in the case of a hole in a part of a drawing. This drawing remains the property of HAVRANEK COMPANY.

100 mm  
 90  
 80  
 70  
 60  
 40  
 30  
 20  
 10  
 0

MICROFILMED

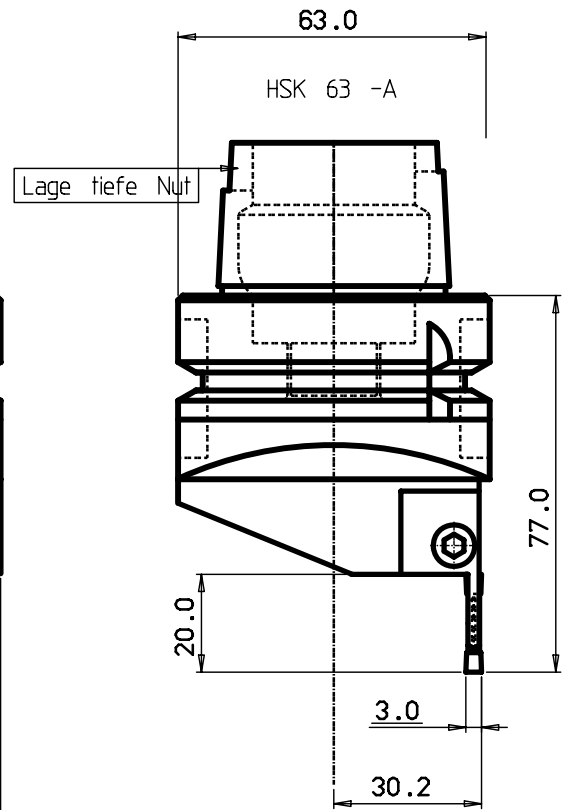
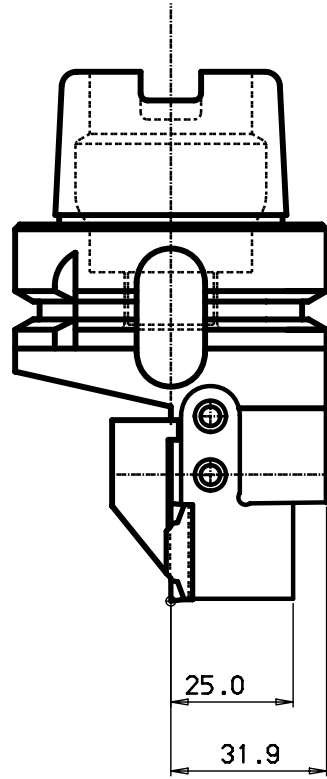
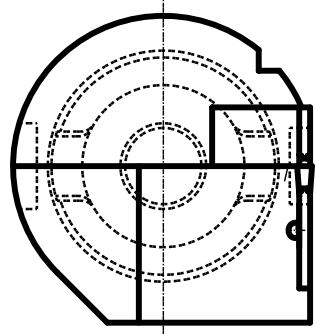

*Plattensitz.Gr. "G"*

5	1	Schraube f. Spannplatte	3212 010-308
4	1	Schraube f. Schwert	5513 020-30
3	1	Schwert	123.27-G
2	1	Spannplatte	R123.27-G
1	1		

Tolerance systems acc to ISO  
 Surface roughness Ra um

Where tolerance not stated:  
 For threads SS-ISO 965/3  
 For dimensions SS 715 Medium

Dimension	Tol	Angle (Shortest adjacent side in mm)	Tol
-6	±0.10		
(6) - 30	±0.20		
(30) - 120	±0.30	10	± 1'
(120) - 315	±0.50	(10) - 50	± 30'
(315) - 1000	±0.80	(50) - 120	± 20'
		(120) -	± 30'

ITEM	QNTY	DESCRIPTION	MATERIAL AND REMARKS	RELATED DRAWING	LIBR	ISSR
CATEGORY	DESIGNED	DRAWN	CHECKED	DATE	SCALE	SUPERSEDES

*Schneidkopf*

REFERENCE

MODIFICATION	AB	C	D	E	F	G	H	I	J	K	L	M	N	P	R	S	T	U	V	X	Y	Z
--------------	----	---	---	---	---	---	---	---	---	---	---	---	---	---	---	---	---	---	---	---	---	---

DESIGN OFFICE | DRAWING NUMBER  
**HSK63A-R123.27G-18-30-77-C**

