

When a hole is to be drilled, the diameter of the hole should be checked before drilling. The drawing shows the property of the drawing.

MICROFILMED

100  
90  
80  
70  
60  
40  
30  
20  
10  
0

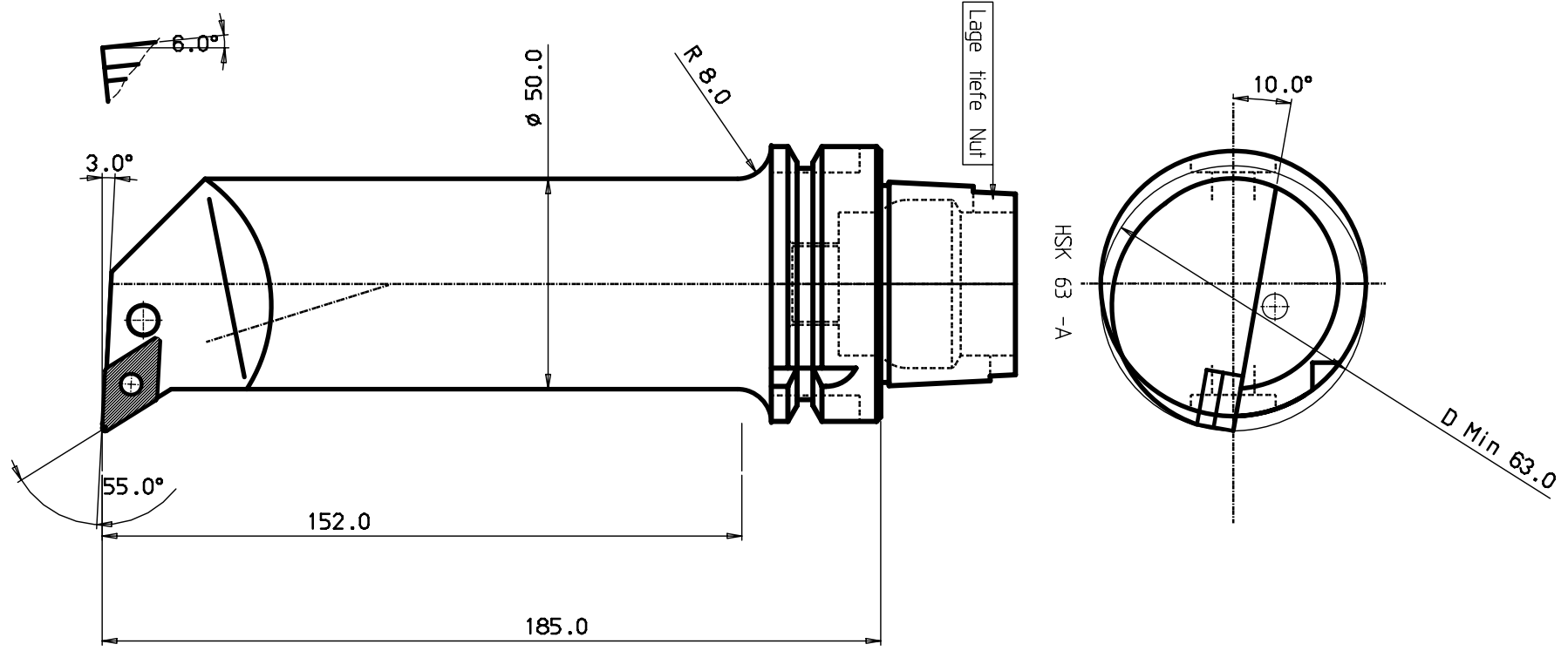

*HM-Platte DN.. 1506..*

5	1	Schraube	174.3-830
4	1	Rohrstift	174.3-861
3	1	Unterlage	171.35-855
2	1	Knihobel	174.3-847M

ITEM	Q'NTY	DESCRIPTION	MATERIAL AND REMARKS	RELATED DRAWING	FORM	SIZE
CATEGORY	DESIGNED	DRAWN	CHECKED	DATE	SCALE	SUPERSEDES

Tolerance systems acc to ISO  
Surface roughness Ra um

Where tolerance not stated  
For threads SS-iso 965/3  
For dimensions SS 7/15 Medium

Dimension	Tol	Angle (Shortest adjacent side in mm)	Tol
(6) - 30	±0.10	10	± 1'
(30) - 120	±0.20	10	± 30'
(120) - 315	±0.30	(10) - 50	± 20'
(315) - 1000	±0.50	(50) - 120	± 20'
		(120) -	± 20'

**Schneidkopf**

REFERENCE: [A][B][C][D][E][F][G][H][J][K][L][M][N][P][R][S][T][U][V][X][Y][Z]

MODIFICATION: [A][B][C][D][E][F][G][H][J][K][L][M][N][P][R][S][T][U][V][X][Y][Z]

DESIGN OFFICE | DRAWING NUMBER

**HSK63A-PDUNR-35185-15**

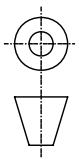

340-0000-2

MOD	LOCATION	CHANGE REFERENCE	DATE	SIGN