

Show of detail and to complete lines of an object and to be used for the purpose of scale and this drawing means the property of the SHAW-WALDMAN

Show of detail and to complete lines of an object and to be used for the purpose of scale and this drawing means the property of the SHAW-WALDMAN

100 mm 90 80 70 60 40 30 20 10 0

100 mm 90 80 70 60 40 30 20 10 0

MICROFILMED

MICROFILMED

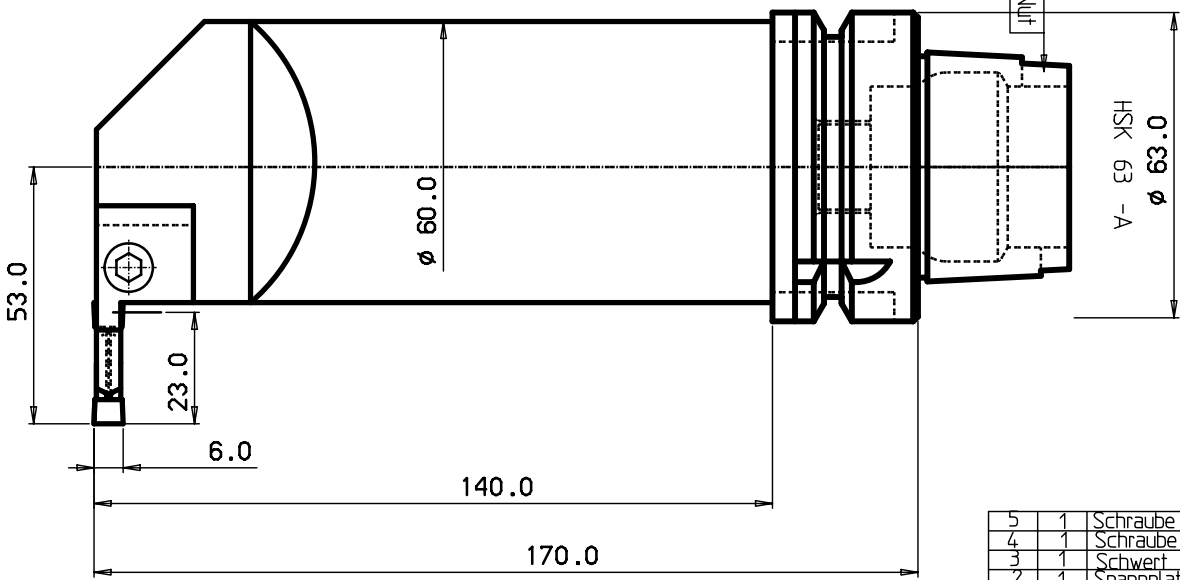
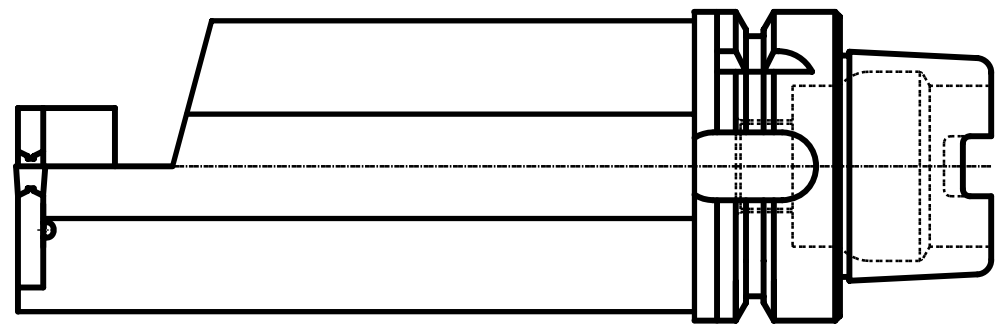

D Min 85.0

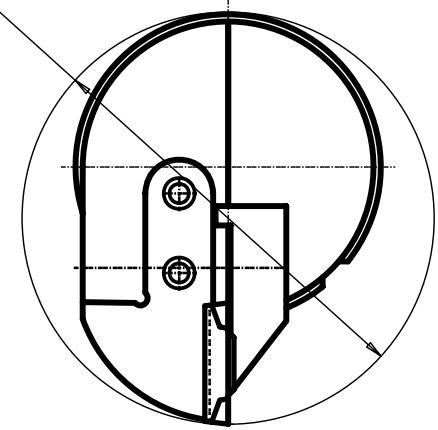

Plattensitz Gr. "K"

5	1	Schraube f. Spannplatte	3212 010-359
4	1	Schraube f. Schwert	5513 020-30
3	1	Schwert	AG 123-K
2	1	Spannplatte	RAG 123-K
1	1		

ITEM	QNTY	DESCRIPTION	MATERIAL AND REMARKS	RELATED DRAWING	ITEM	SIZE
CATEGORY	DESIGNED	DRAWN	CHECKED	DATE	SCALE	SUPERSEDES

TITLE

Schneidkopf



REFERENCE	MODIFICATION	DESIGN OFFICE	DRAWING NUMBER
			HSK63A-RAG-123K

Tolerance systems acc to ISO
Surface roughness Ra um

Where tolerance not stated:
For threads SS-iso 965/3
For dimensions SS 715 Medium

Dimension	Tol	Angle (Shortest adjacent side in mm)	Tol
(6) - 30	+0.10	0	± 1'
(30) - 120	+0.20	0	± 30'
(120) - 315	+0.50	(50) - 120	± 20'
(315) - 1000	+0.80	(120) -	± 30'

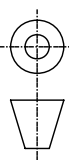

340-00100-2

340-00100-2

1 2 3 4 5 6 7 8