

Show in profile over the complete length of the part
 and to be used when the part is not shown in
 this drawing unless the part is a shaft or column

100 mm
 90
 80
 70
 60
 40
 30
 20
 10
 0

MICROFILMED

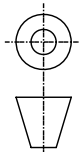

340-CFD00-2

HSK03A-123L-283211U-B

MOD: LOCATION	CHANGE REFERENCE	DATE	SIGN	1500 (15)	1000	150 (120)	-120 ± 20 ± 10	7	8
---------------	------------------	------	------	--------------	------	--------------	----------------------	---	---

DESIGN OFFICE	DRAWING NUMBER
---------------	----------------

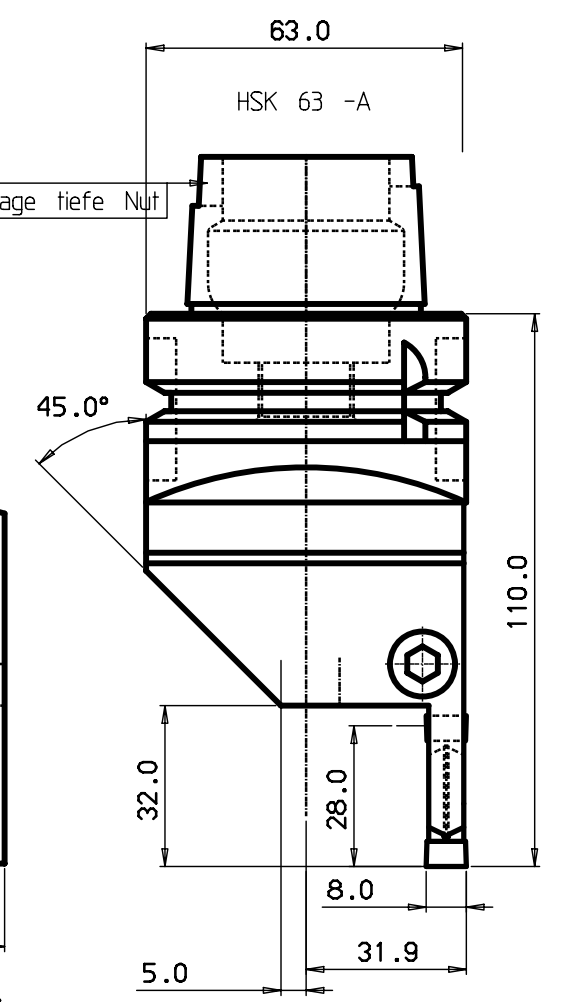
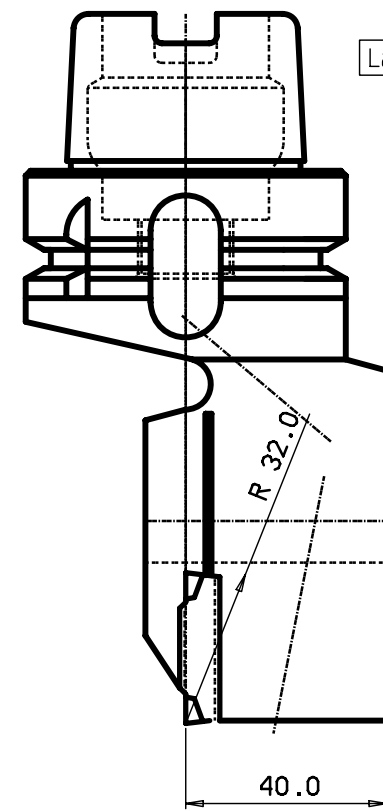
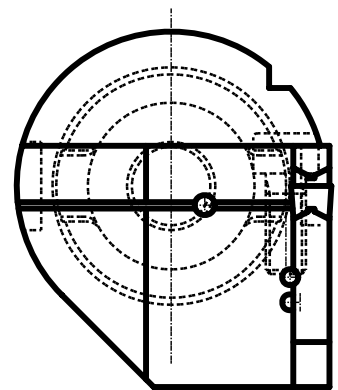

Pattensitz Gr. "L"

3	1	Gewindestift	M4x10
2	1	Schraube	
1	1		

ITEM	QNTY	DESCRIPTION	MATERIAL AND REMARKS	RELATED DRAWING	ITEM	SIZE
CATEGORY	DESIGNED	DRAWN	CHECKED	DATE	SCALE	SUPERSEDES

Tolerance systems acc to ISO
 Surface roughness Ra um
 Where tolerance not stated
 For threads SS-iso 965/3
 For dimensions SS 715 Medium

Dimension	Tol	Angle (Shortest adjacent side in mm)	Tol
-6	±0.10	10	± 1'
(6) - 30	±0.20		± 30'
(30) - 120	±0.30	(10) - 50	± 20'
(120) - 315	±0.50	(50) - 120	± 20'
(315) - 1000	±0.80	(120) -	± 10'

Schneidkopf



MODIFICATION	1	A B C D E F G H J K L M N P R I S T U V X Y Z
DESIGN OFFICE	DRAWING NUMBER	HSK63A-123L-283211U-B

MOD: LOCATION	CHANGE REFERENCE	DATE	SIGN	1500 (15)	1000	150 (120)	-120 ± 20 ± 10	7	8
---------------	------------------	------	------	--------------	------	--------------	----------------------	---	---